

RRA KEYNOTE LEGEND	
KEYNOTE	KEYNOTE TEXT
SD-1a	TABLE EDGE - TURN DOWN
SD-7	CABINET BASE - WELDED CONSTRUCTION
SD-12	SINK ENCLOSURE - WALL & SINGLE ISLAND
SD-14b	15"X20"X5" DP_DRAWER
SD-38	STAINLESS STEEL WALL PANEL
SD-123	CASHIER COUNTER DETAIL
SD-135	THERMAL BREAK @ WELL CUTOUTS

FINISH SCHEDULE			
PCT-11	MANUFACTURER: BACK BAY STYLE: ET-15 COLOR: ETIC PALISSANDRO SIZE: 4" X 36", 6" X 36", 8" X 36"	PLAM-1	MANUFACTURER: PIONITE PATTERN: WM115 SUGAR MAPLE 11 FINISH: SUEDE
PCT-13	MANUFACTURER: DAL TILE STYLE: COLORWAVE COLOR: CW01 ICE WHITE STD SIZE: 1" X 1" GLASS MOSIAC	MP-1	MANUFACTURER: RIGIDIZED METAL PATTERN: SANDTEX
PCT-14	MANUFACTURER: DAL TILE STYLE: COLORWAVE COLOR: CW28 EVENING MIXER STD SIZE: 1" X 1" GLASS MOSIAC	DOOR PULL	MANUFACTURER: HAFELE MODEL: 124.02.920 FINISH: ANODIZED SILVER
SS-1	MANUFACTURER: ZODIAQ COLOR: CLOUD WHITE THICKNESS: 3cm	** VERIFY FINAL FINISH SELECTION & SUBMIT SAMPLE TO ARCHITECT/INTERIORS FOR APPROVAL PRIOR TO FABRICATION. GRAIN OF LAMINATE TO RUN VERTICAL UNLESS OTHERWISE NOTED. **	
SS-2	MANUFACTURER: ZODIAQ COLOR: STORM GREY THICKNESS: 3cm		

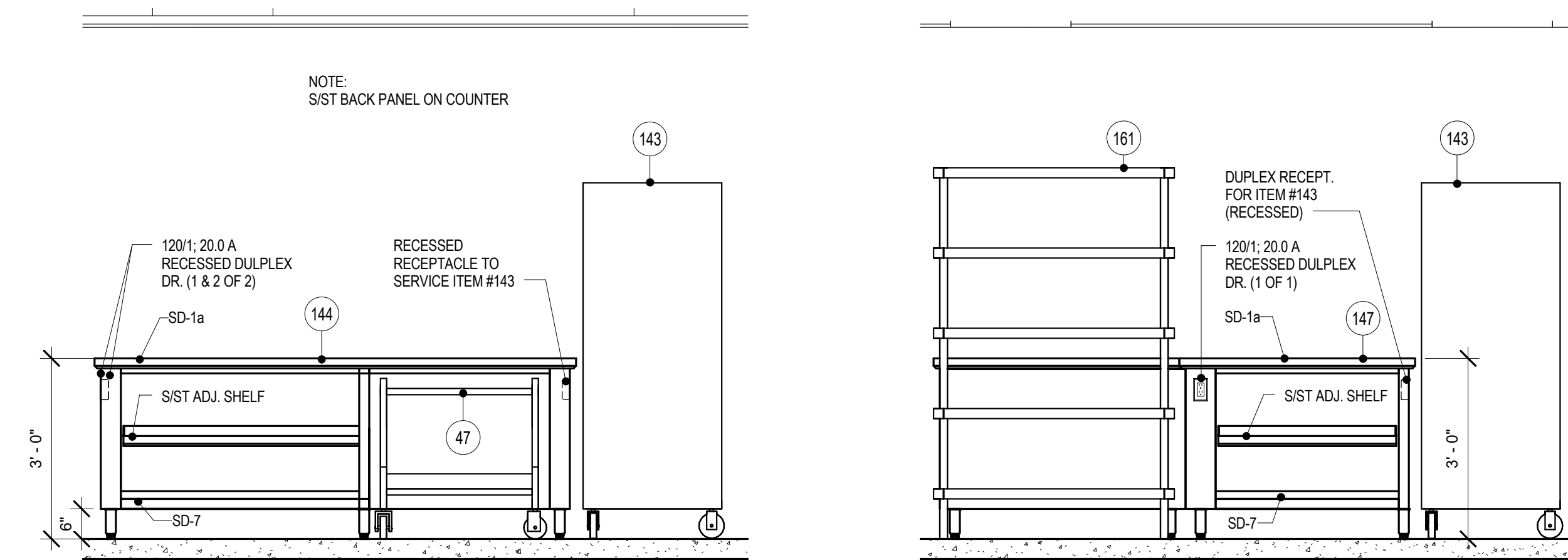

1 ITEM #144 - WORKCOUNTER
1/2" = 1'-0"

2 ITEM #147 - WORKCOUNTER
1/2" = 1'-0"

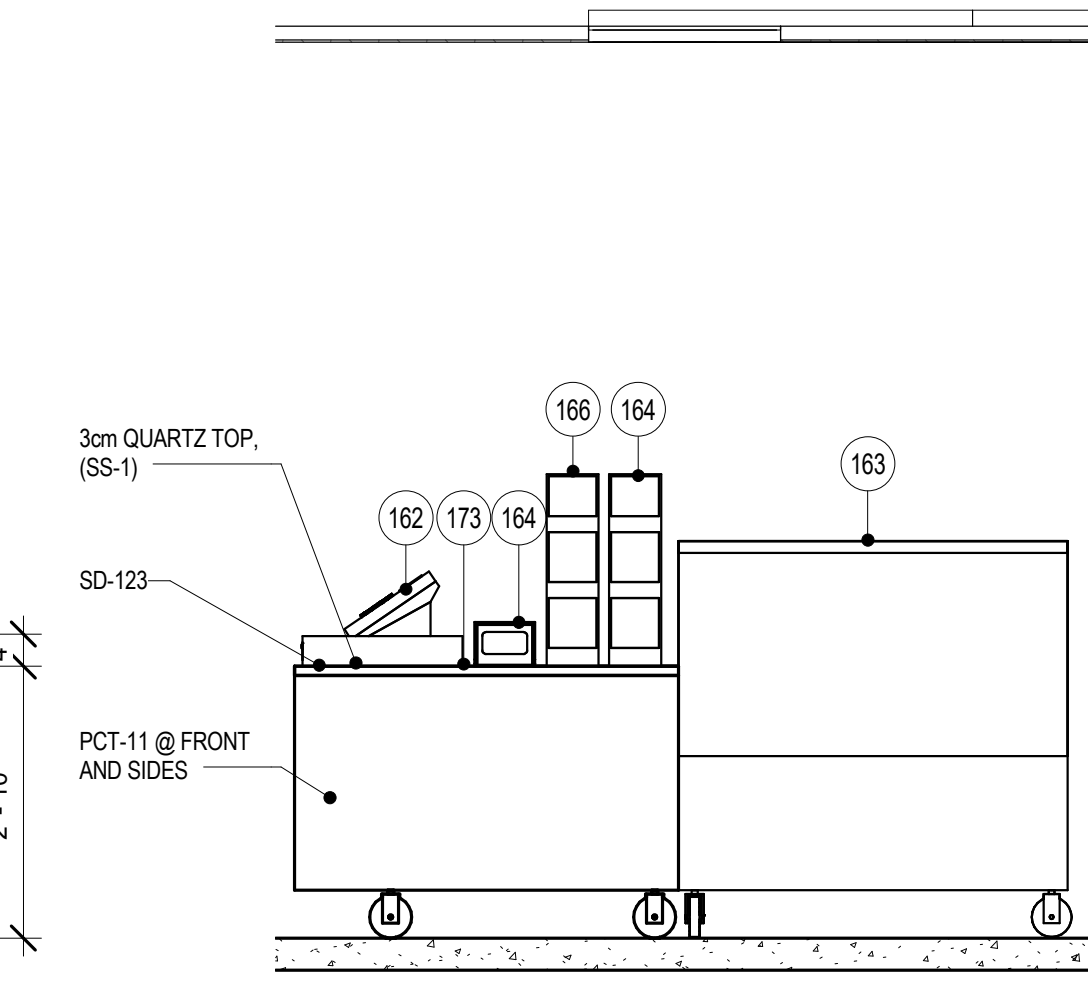
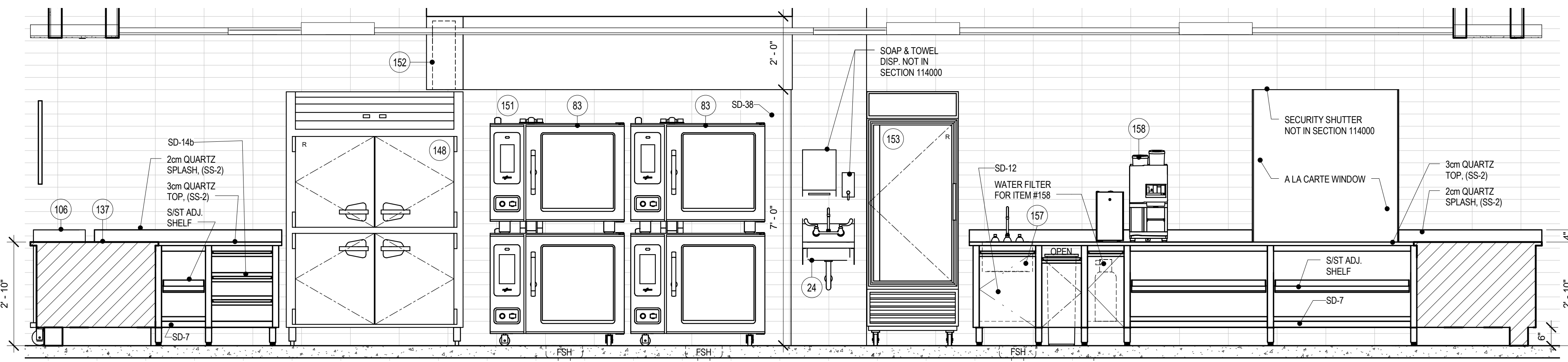

4 ITEM #173 - MOBILE CASHIER STAND
1/2" = 1'-0"

3 ITEM #149 - EXHAUST HOOD
1/2" = 1'-0"

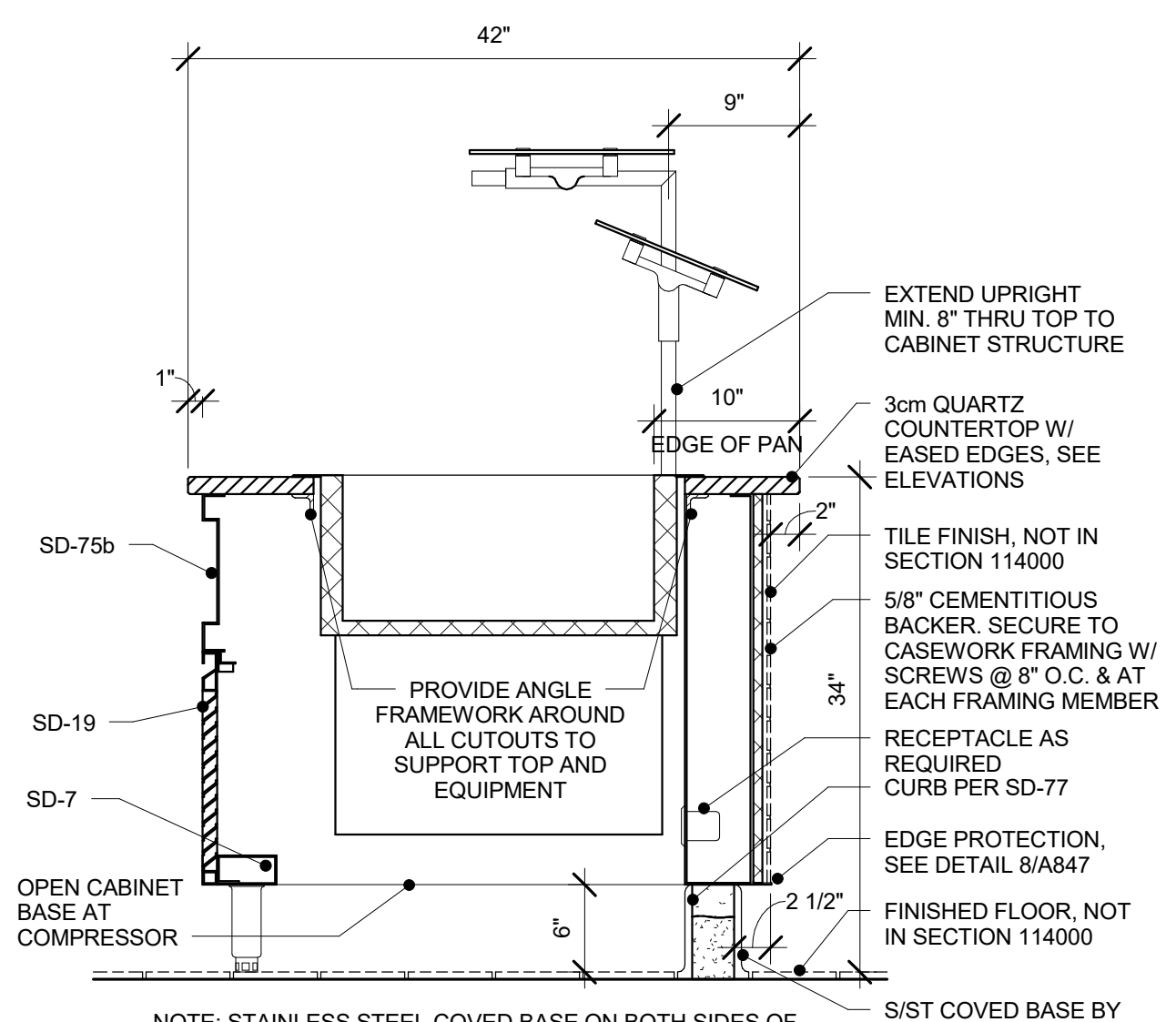

5 SECTION THRU COLD WELL-TILE
1" = 1'-0"

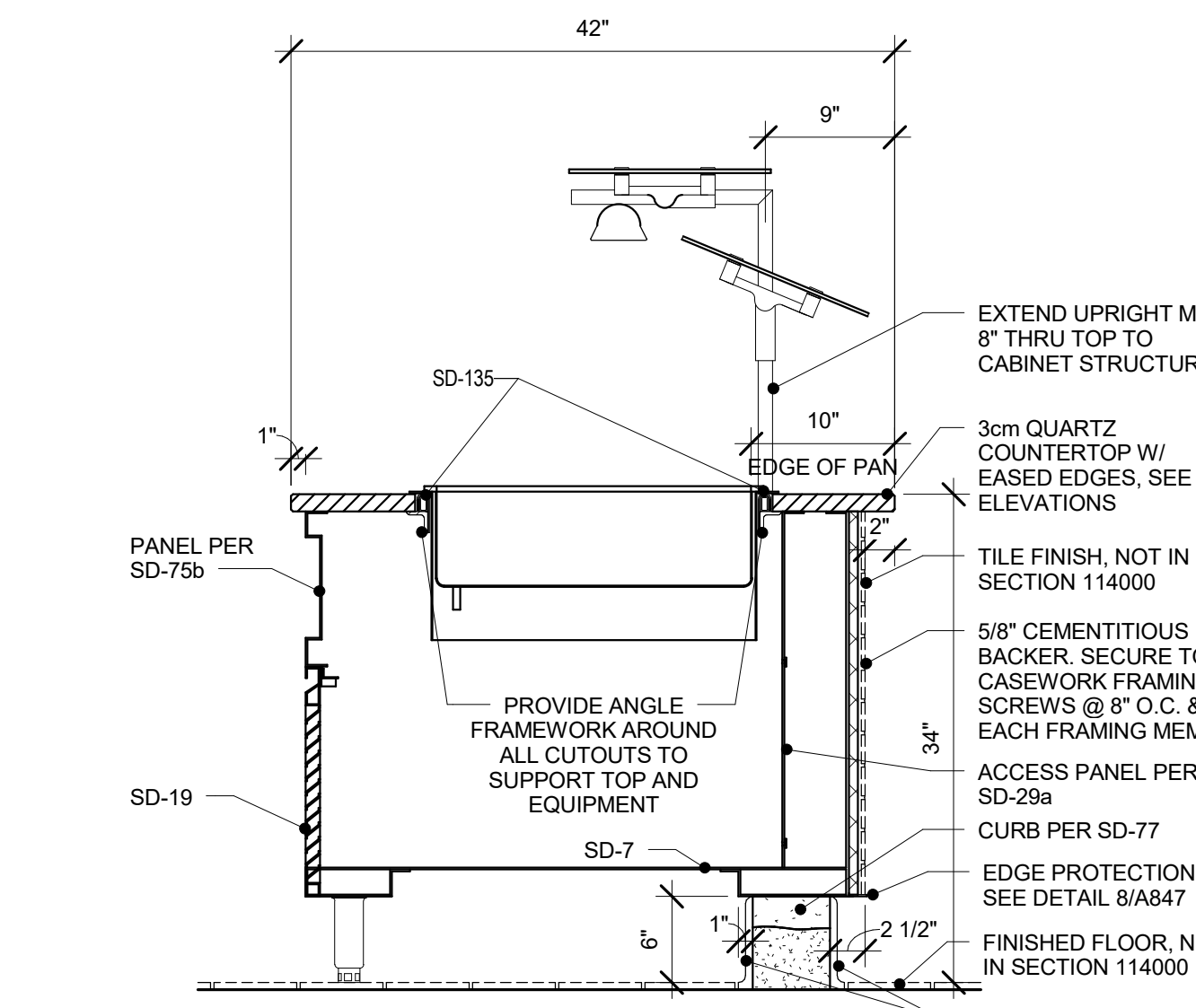

6 SECTION THRU HOT WELL-TILE
1" = 1'-0"

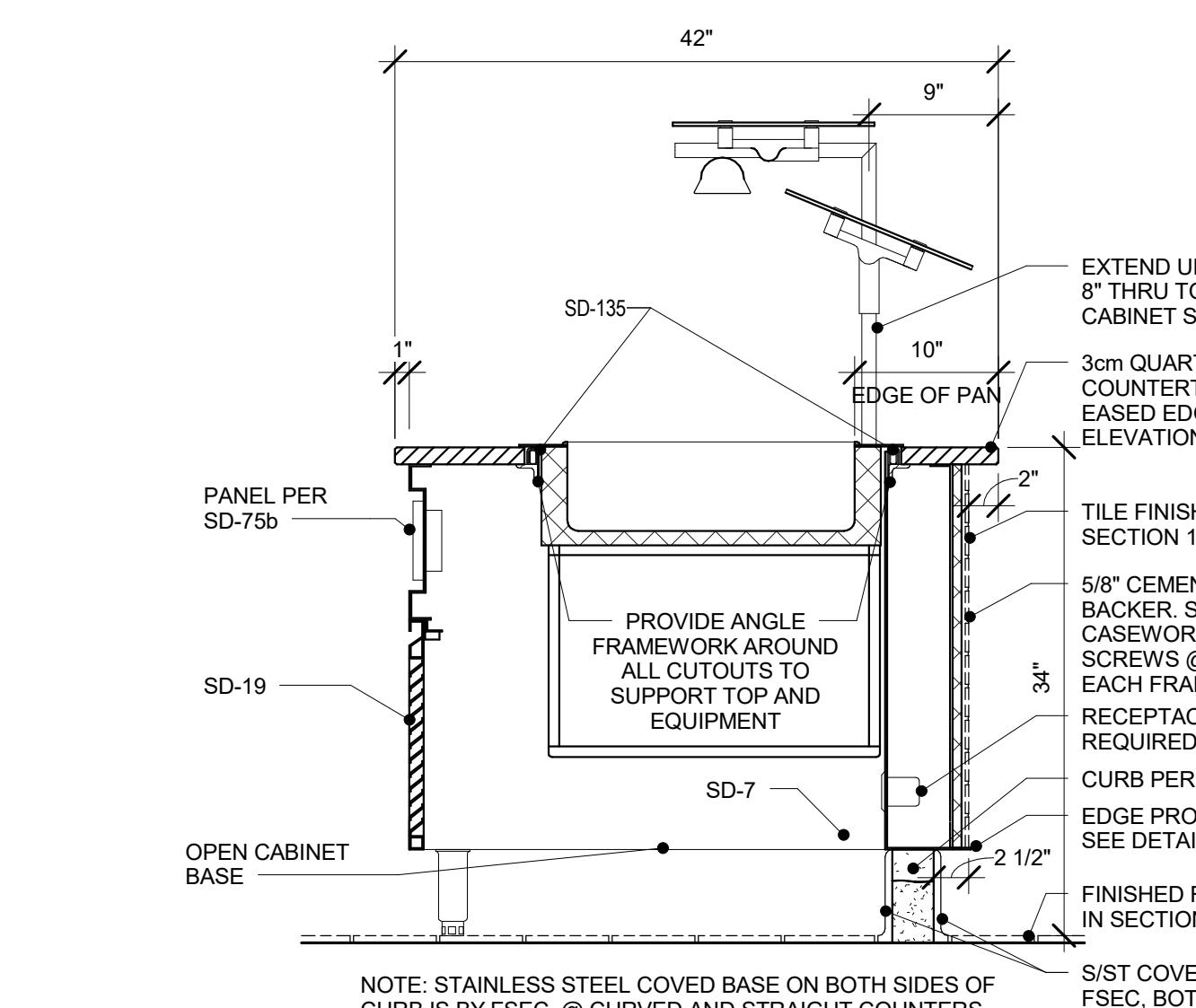

7 SECTION THRU HOT/COLD WELL-TILE
1" = 1'-0"

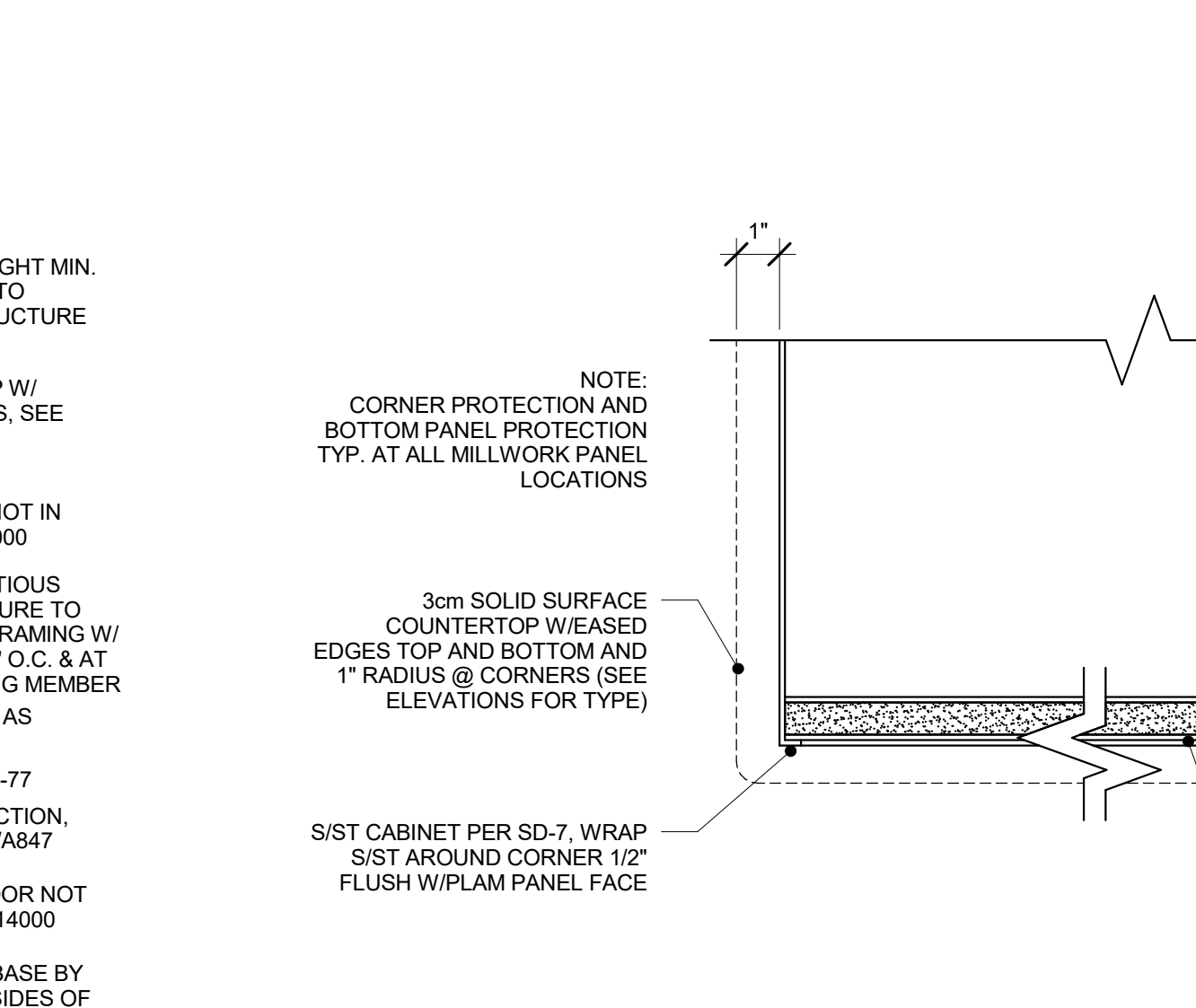

8 TYPICAL EDGE PROTECTION DETAIL
3" = 1'-0"

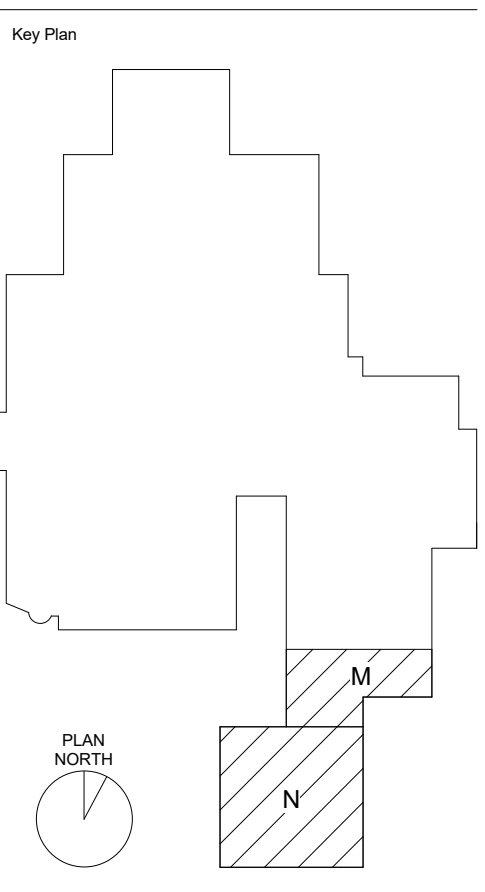

Sheet Issue Date	100% CD SET	04/07/2017
Previous Issue Date	100% DD SET	11/11/2016
	95% CD SET	03/20/2017
Revision		Date

CONSTRUCTION DOCUMENTS

Drawing
FOODSERVICE EQUIPMENT ELEVATIONS AND SECTION